

* V means 1500V module

HT60-156P HT60-156P(V)

POWER OUTPUT

270W / 275W 280W / 285W / 290W



- Module Efficiency: 17.8%
- No. of Cells: 60 (6 × 10)
- Weight: 18.5kg
- Dimensions: 1640mm×992mm×35mm

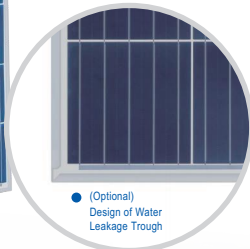

● (Optional)
Design of Water
Leakage Trough

Polycrystalline
156.75 × 156.75mm



Shanghai Aerospace Automobile
Electromechanical Co., Ltd.
website: www.ht-saae.com



Factory :
Lianyungang ShenZhou New Energy Co., Ltd.
Turkey HT Solar Energy Joint Stock Company

PID
PID Resistant



Designed for high voltage systems of up to 1500 VDC, increasing the string length of solar systems and saving on BoS costs



Advanced surface treatment, lower surface reflection and 5BB cell design can reduce the series resistance and improve the module efficiency

1000Pa

Certified to withstand dynamic mechanical load 1000 Pascal



Microcrack resistant
Triple EL tested of high quality control.



Entire module certified to withstand extreme wind (2400 Pa) and snow loads (5400 Pa)



Ammonia / Salt Mist
Corrosion resistant

2%

All the modules are sorted and packaged by amperage, reducing mismatch losses and maximizing system output.

Comprehensive and first-rate certification system

IEC61215: 2016, IEC61730: 2016 Latest Standard
ISO9001, ISO14001 and OHSAS18001,
meeting the highest international standards
Strict quality control

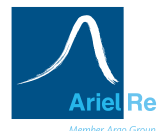

* Copyright@2018V3 Specifications are subject to change without further notification

* Copyright@2018V3 Specifications are subject to change without further notification

Engineering Drawing

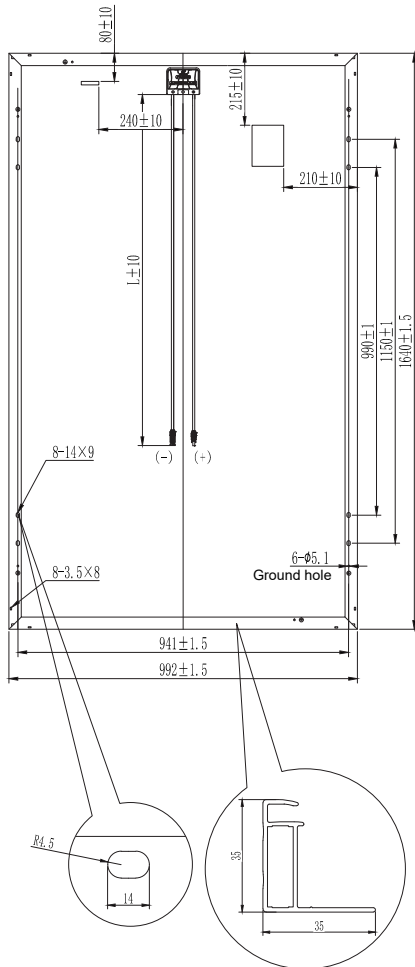

Electrical Characteristics

Module	HT60-156P / HT60-156P(V)				
Maximum Power at STC(Pmax)	270W	275W	280W	285W	290W
Open-Circuit Voltage(Voc)	37.9	38.2	38.5	38.7	38.9
Short-Circuit Current(Isc)	9.38	9.47	9.56	9.69	9.82
Optimum Operating Voltage (Vmp)	30.8	31	31.2	31.5	31.7
Optimum Operating Current(Imp)	8.78	8.88	8.98	9.06	9.16
Module Efficiency	16.6%	16.9%	17.21%	17.52%	17.83%
Power Tolerance	0 ~ +5W				
Maximum System Voltage	1000V / 1500V DC(IEC)				
Maximum Series Fuse Rating	15A				
Operating Temperature	-40 °C to +85 °C				

*STC: Irradiance 1000W/m², module temperature 25, AM=1.5
Optional black frame or white frame module according to customer requirements

NOCT

Module	HT60-156P / HT60-156P(V)				
Maximum Power	199	203	207	210	214
Open Circuit Voltage (Voc)	35.6	35.9	36.2	36.3	36.5
Short Circuit Current (Isc)	7.58	7.65	7.72	7.83	7.93
Maximum Power Voltage (Vmp)	28.9	29.1	29.3	29.6	29.8
Maximum Circuit Current (Imp)	6.89	6.98	7.06	7.09	7.18
NOCT	45°C ±2°C				

*NOCT: Irradiance 800W/m², ambient temperature 20 °C, wind speed 1 m/s

Mechanical Characteristics

Solar Cells	Polycrystalline 156.75 × 156.75mm
No. of Cells	60 (6 × 10)
Dimensions	1640mm × 992mm × 35mm
Weight	18.5kg
Front Glass	High transmission tempered glass
Frame	Anodized aluminium alloy
Junction Box	IP68
Cable	4mm ² (IEC)
Connectors	MC+ / MC- Compatible
Packaging Configuration	31pcs / box, 868pcs / 40'HQ Container

Temperature Characteristics

Temperature Coefficient of Pmax	γ (Pm)	-0.41%/K
Temperature Coefficient of Voc	β (Voc)	-0.32%/K
Temperature Coefficient of Isc	α (Isc)	0.050%/K

I-V Curves

Current-Voltage & Power-Voltage Curve

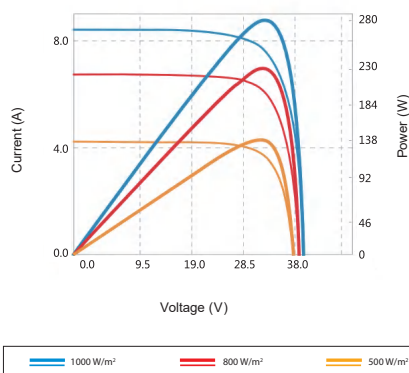

Warranty

- 12-year product warranty
- 25-year warranty on power output
- Specific information is referred to the product quality guarantee

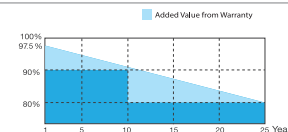

Information Box